

HL-304S42FC

HL-304S42FC

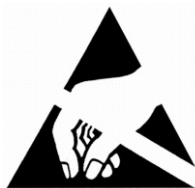

ATTENTION 注意
OBSERVE PRECAUTIONS
FOR HANDLING
ELECTROSTATIC
DISCHARGE
SENSITIVE
DEVICES
请勿裸手接触器件

Features (特征)

- φ 3 LAMP LED 直插φ 3 LED 灯
- LOW POWER CONSUMPTION.低功耗
- CABINED VIEWING ANGLE.小角度
- IDEAL FOR BACKLIGHT AND INDICATOR.
用于背光和指示
- PACKAGE: 1000PCS / BAG.包装:1000PCS/袋

Package Dimensions 封装尺寸

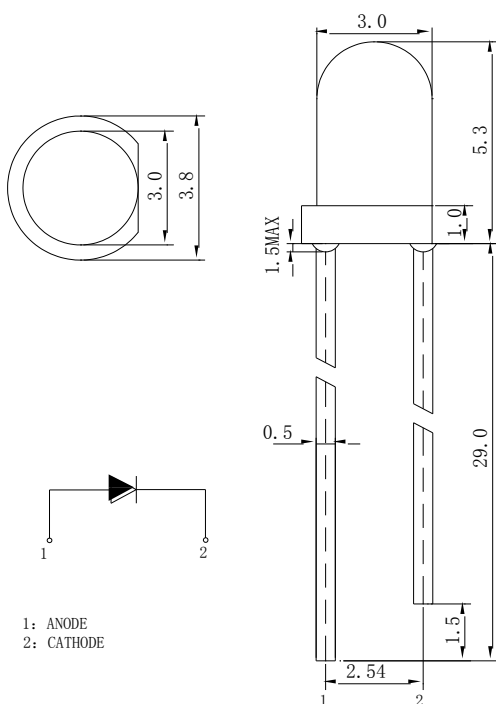

Description(描述)

This devices are made with GaAs.
LED 芯片组成元素为 GaAs.



Tolerance Grade 公差等级	Dimension Tolerance (UNIT:mm) 尺寸公差 (单位:mm)			
	0.5~3	3~6	6~30	30~120
	±0.1	±0.2	±0.3	±0.5
	Chip 晶片		Lens Color 透镜颜色	
Material 材料	Color Transparent 无色透明		Water Clear 无色透明	
GaAs	Red			

■ Absolute Maximum Rating (最大数值)

Item 名称	Symbol 符号	Value 数值	Unit 单位
Forward Current 正向电压	IF	20	mA
Peak Forward Current* 峰值正向电流	IFP	100	mA
Reverse Voltage 反向电压	VR	5	V
Power Dissipation 功耗	PD	80	mW
Electrostatic discharge (HBM) 抗静电能力	ESD	10	KV
Operation Temperature 操作温度	Topr	-30~+80	°C
Storage Temperature 储存温度	Tstg	-30~+80	°C
Lead Soldering Temperature* 引脚焊接温度	Tsol	Max. 260°C for 5sec Max.	

*IFP Conditions: Pulse Width ≤ 10msec (IFP 正向峰值电流使用条件: 脉冲宽度 ≤ 10 毫秒)

*Tsol Conditions: 3mm from the base of the epoxy bulb

(Tsol 焊接条件: 焊接位置离胶体底部 3 毫米)

■ The percentage of ESD approved is 90%(ESD 的通过率为 90%)

■ Typical Optical/ Electrical Characteristics Ta=25°C (光电参数 环境温度 25°C)

Item (名称)	Symbol 符号	Condition 条件	Rank 档次	Min. 最小值	Typ. 典型值	Max. 最大值	Unit 单位
Luminous Intensity 光强	Iv	IF=20mA	T	1320		1715	mcd
			U	1715		2230	mcd
			V	2230		2900	mcd
Forward Voltage 正向电压	VF			1.8	2.2	2.6	V
Viewing Angle 角度	2θ 1/2			--	25	--	deg
Dominant Wavelength 主波长	λD				618	--	628
Recommend Forward Current 推荐使用正向电流	IF(rec)	--		--	--	20	mA
Reverse Current 反向电流	IR	Vr=5V		--	--	20	uA

Notes (注释):

Tolerance : VF ± 0.1V, λ d ± 2 nm, IV(φ V) ± 15%, 2θ 1/2 ± 15%

公差: 正向电压 ± 0.1V, 主波长 ± 2 nm, 光强 (光通量) ± 15%, 角度 ± 15%

Reliability Performance 可靠性
Test Items And Result 测试项目和判定

Test Classification 测试类别	Test Item 测试项目	Test Conditions 测试条件	Test Duration 测试持续时间	Sample Size 样品数量	AC/RE 接受/拒收
Life Test 寿命测试	Room Temperature DC Operating Life Test 室温直流寿命测试	$T_a=25^{\circ}\text{C}\pm 5^{\circ}\text{C}$, $I_f=20\text{mA}$	1000 hrs	22 pcs	0/1
Environment Test 环境模拟实验	Thermal Shock Test 冷热冲击	$100^{\circ}\text{C}\pm 5^{\circ}\text{C}$ 5min ↑ ↓ $-40^{\circ}\text{C}\pm 5^{\circ}\text{C}$ 5min.	100 cycles	22 pcs	0/1
	Temperature Cycle Test 高低温循环实验	$100^{\circ}\text{C}\pm 5^{\circ}\text{C}$ 30min ↑ ↓ 5min $-40^{\circ}\text{C}\pm 5^{\circ}\text{C}$ 30min.	100 cycles	22 pcs	0/1
	High Temperature & High Humidity Test 高温高湿实验	$85^{\circ}\text{C}\pm 5^{\circ}\text{C}/85\% \text{RH}$ $I_f=5\text{mA}$	1000 hrs	22 pcs	0/1
	High Temperature Storage 高温储存	$T_a=100^{\circ}\text{C}\pm 5^{\circ}\text{C}$	1000 hrs	22 pcs	0/1
	Low Temperature Storage 低温储存	$T_a=-40^{\circ}\text{C}\pm 5^{\circ}\text{C}$	1000 hrs	22 pcs	0/1
Mechanica Test 机械测试	Resistance to Soldering Heat 耐焊接实验	Temp= 260°C max T=5sec max	1 times	22 pcs	0/1
	Lead Integrity 引脚折弯实验	Load 2.5N(0.25kgf) $0^{\circ} \sim 90^{\circ} \sim 0^{\circ}$	3 times	22 pcs	0/1

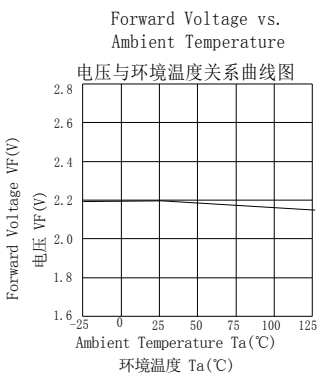
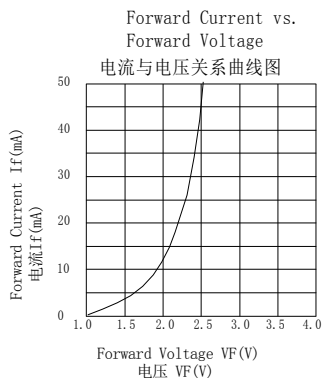
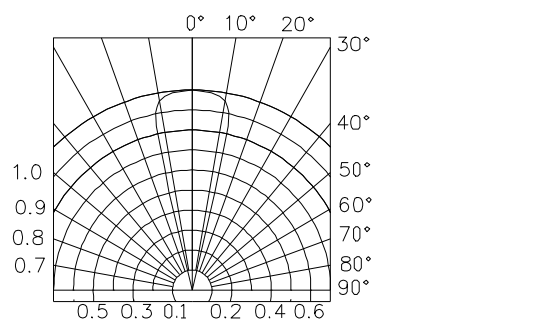
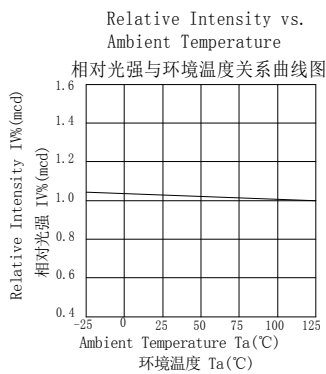
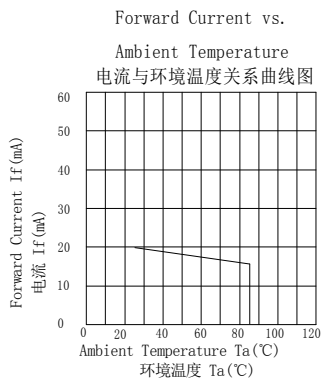

Soldering (焊接) :

1. Manual Of Soldering (手工焊接)

The temperature of the iron tip should not be higher than 300°C and Soldering within 3 seconds per solder-land is to be observed. (烙铁最高温度不高于 300°C, 焊接时间小于 3 秒)

2. DIP soldering (Wave Soldering)波峰焊接:

Preheating: 120°C~150°C, within 120~180 sec. (预热温度 120°C~150°C, 小于 120~180 秒)

Operation heating: 245°C ± 5°C within 5 sec. 260°C (Max)

操作温度: 245°C ± 5°C 小于 5 秒, 最高温度不高于 260°C

Gradual Cooling (Avoid quenching).

过完波峰焊后应缓慢冷却

