

HL-503IR3C-L3

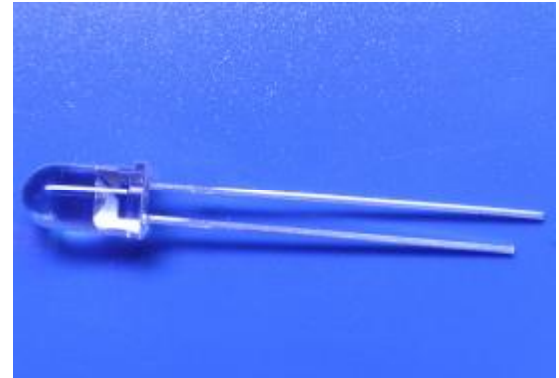

HL-503IR3C-L3



**Features**

- Mechanically and spectrally matched to the phototransistor.
- Rohs compliant.

**Package Dimensions**

**Description**

This devices are made with PIN GaAs.

1: ANODE  
2: CATHODE

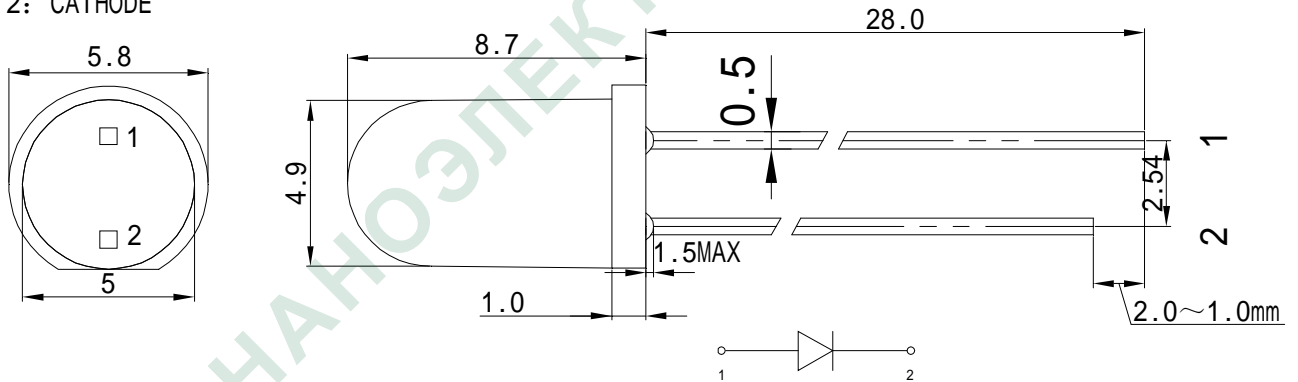

Tolerance Grade	Dimension Tolerance (UNIT:mm)			
	0.5~3	3~6	6~30	30~120
	±0.1	±0.2	±0.3	±0.5
Chip		Lens Color		
Material	Emitting Color	Water Clear		
GaAs	/			

**Selection Guide**

Part No	Radiant Intensity(mW/sr) $I_F=50mA$		Viewing Angle
	Min	Typ	2θ1/2 (供参考)
HL-503IR3C-L3	--	71	20

**Note:**

1. 2θ1/2 is the angle from optical centerline where the luminous intensity is 1/2 the optical centerline value.
2. Tolerance of measurement of luminous intensity±15%.

**Electrical / Optical Characteristics at TA=25°C**

Item	Symbol	Min	Typ	Units	Test Conditions
Forward Voltage	$V_F$	1.2	1.5	V	$I_F=50mA$
Reverse Current	$I_R$	--	10	uA	
Peak Spectral Wavelength	$\lambda_D$	--	940	nm	
Spectral Bandwidth	$\Delta \lambda_{1/2}$	--	50	nm	

**Note:**

1. Tolerance of measurement of forward voltage±0.1V.
2. Tolerance of measurement of peak Wavelength±2.0nm.

**Absolute Maximum ratings at Ta=25°C**

Parameter	Symbol	IR1	Units
Power Dissipation	$P_t$	100	mW
DC Forward Current	$I_F$	50	mA
Peak Forward Current[1]	$i_{FS}$	300	mA
Operating Temperature		-30°C ~80°C	
Storage Temperature		-30°C ~80°C	

**Note:**

1. IFP Conditions: Pulse Width≤10msec
2. Tsol Conditions: 3mm from the base of the epoxy bulb

**HL-503IR3C-L3**

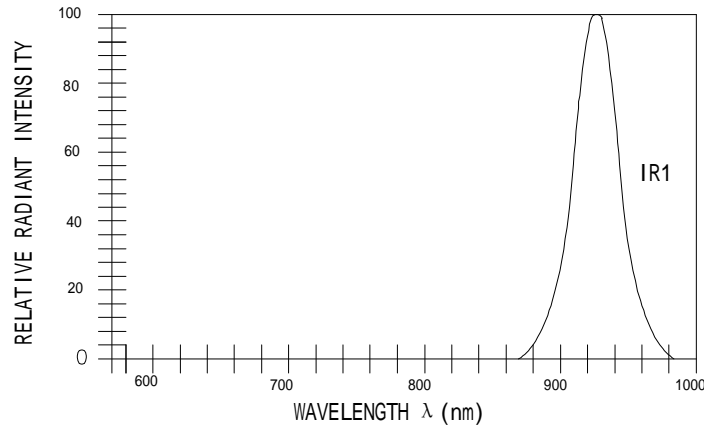

Forward Current vs.Forward Voltage

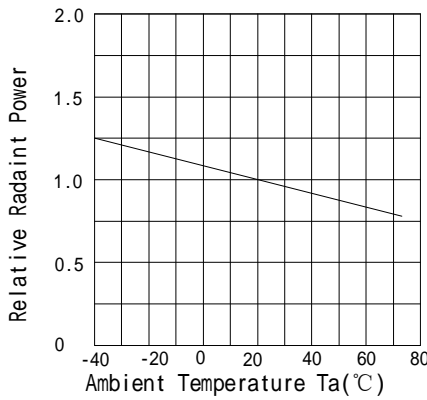

Radint Power Vs.Ambient Temperature

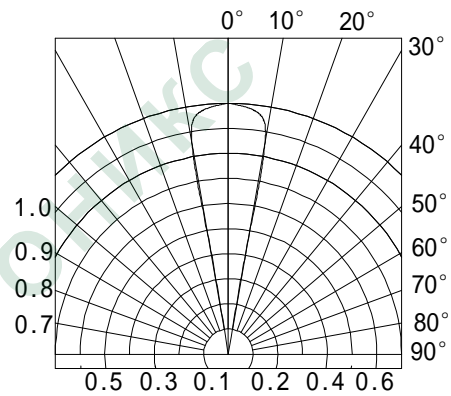

Spatial Distribution

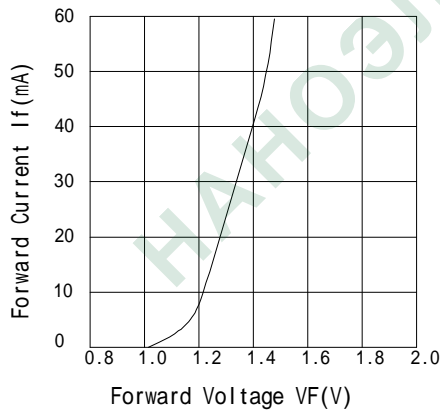

Forward Current Vs.Forward Voltage

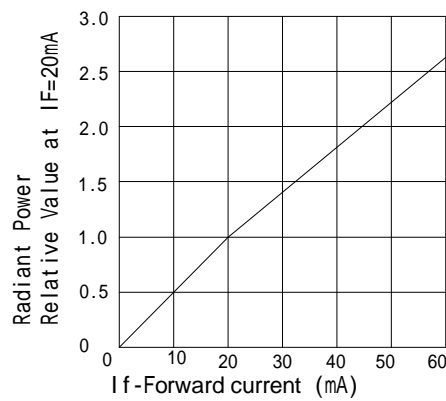

Radint Power Vs Forward Current

Remarks:

If special sorting is required (e.g.binning based on forward voltage or radiant intensity/luminous flux),the typical accuracy of the sorting process is as follows:

1. Radiant intensity/Luminous Flux:±15%.
2. Forward Voltage:±0.1V.

Note:Accuracy may depend on the sorting parameters.

## Soldering:

### 1. Manual Of Soldering

The temperature of the iron tip should not be higher than 300°C and Soldering within 3 seconds per solder-land is to be observed.

### 2. DIP soldering (Wave Soldering):

Preheating: 120°C~150°C, within 120~180 sec.

Operation heating: 245°C ± 5°C within 5 sec. 260°C (Max)

Gradual Cooling (Avoid quenching).

