

HL-503PD4C-T



HL-503PD4C-T



**Features**

- Mechanically and spectrally matchend to the infrared emitting LED LAMP.
- Navy Blue Lens
- Rohs compliant.

**Package Dimensions**

**Description**

Made with PIN silicon photo-diode chips.

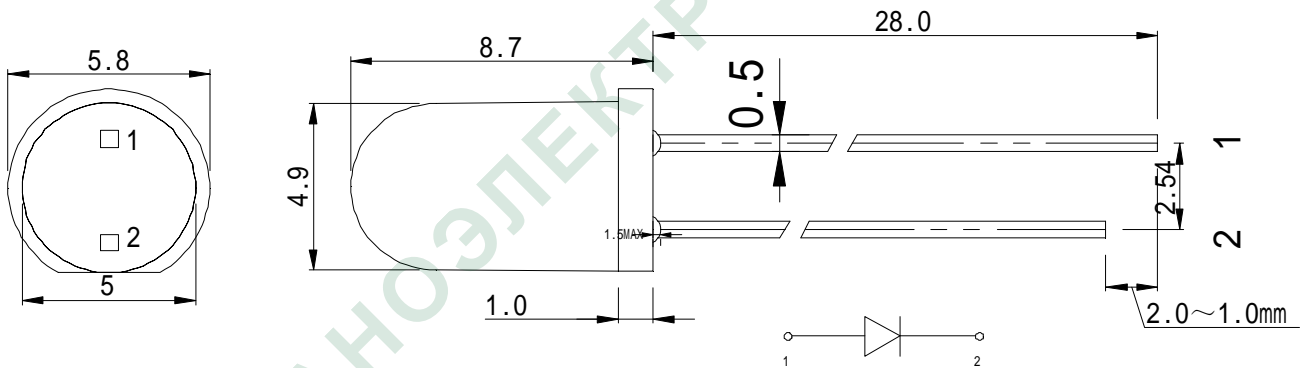

Tolerance Grade	Dimension Torlerance (UNIT:mm)			
	0.5~3	3~6	6~30	30~120
	±0.1	±0.2	±0.3	±0.5

**Electrical / Optical Characteristics at TA=25°C**

Symbol	Parameter	Min	Typ	Max	Units	Test Conditions
$V_{BR\ CE0}$	Collector-Emitter Breakdown Voltage	35	-	-	V	$I_C=100\mu A$ $E_e=0mW/cm^2$
$V_{BR\ EC0}$	Emitter-to-Collector Breakdown Voltage	5	-	-	V	$I_e=100\mu A$ $E_e=0mW/cm^2$
$V_{CE(SAT)}$	Collector-to-Emitter Saturation Voltage	-	-	0.8	V	$I_C=100\mu A$ $E_e=20mW/cm^2$
$I_{CEO}$	Collector Dark Current	-	-	100	nA	$V_{CE}=100\mu A$ $E_e=0mW/cm^2$
$T_R$	Rise Time (10% to 90%)	-	3	-	us	$V_{CE}=5V$ $I_C=1mA$ $R_L=1000$
$T_F$	Fall Time (90% to 10%)	-	3	-	us	
$I_{(ON)}$	On State Collector Current	0.1	0.5	-	mA	$V_{CE}=5V$ $E_e=1mW/cm^2$ $\lambda=940nm$

**Absolute Maximum ratings at Ta=25°C**

Parameter	Max Ratings
Collector-to-Emitter Breakdown Voltage	35V
Emitter-to-Collector Breakdown Voltage	5V
Power Dissipation at (or below) 25°C Free Air Temperature	100mW
Operating Temperature Range	-30°C~80°C
Storage Temperature Range	-30°C~80°C
Lead Soldering Temperature (>3mm for 5sec)	260°C

## Soldering:

### 1. Manual Of Soldering

The temperature of the iron tip should not be higher than 300°C and Soldering within 3 seconds per solder-land is to be observed.

### 2. DIP soldering (Wave Soldering):

Preheating: 120°C~150°C, within 120~180 sec.

Operation heating: 245°C ± 5°C within 5 sec. 260°C (Max)

Gradual Cooling (Avoid quenching).

